

In-line CNC Coordinate Measuring System MACH Series



In-line CNC Coordinate Measuring System

MACH Series

High-Speed In-line Coordinate Measuring Machine, Bursting out of the Inspection Room.

An absolute requirement for a measuring machine to operate around the clock in a factory is the structural design: with due consideration given to superior durability for stable operations, significant reduction in measuring time, accuracy assurance under a wide range of temperature environments, security and ease of maintenance. The MACH Series is Mitutoyo's in-line CNC coordinate measuring system that meets these demanding criteria.

The proof is the fact that this series has established trust and a track record, particularly in the automobile industry at home and abroad.

Vertical and Flexible MACH-V

MACH-V provides a flexible measurement system capable of replacing series of gage measurements on a powertrain manufacturing line. The high acceleration, high-speed probe movement results in high-throughput measurement.

Horizontal and High-speed Driven MACH-3A

This is a horizontal CNC coordinate measuring system that achieves high throughput by increased drive speed, acceleration, and measuring speed.

Space-saving and durability characteristics are compatible with line-side/in-line installation.

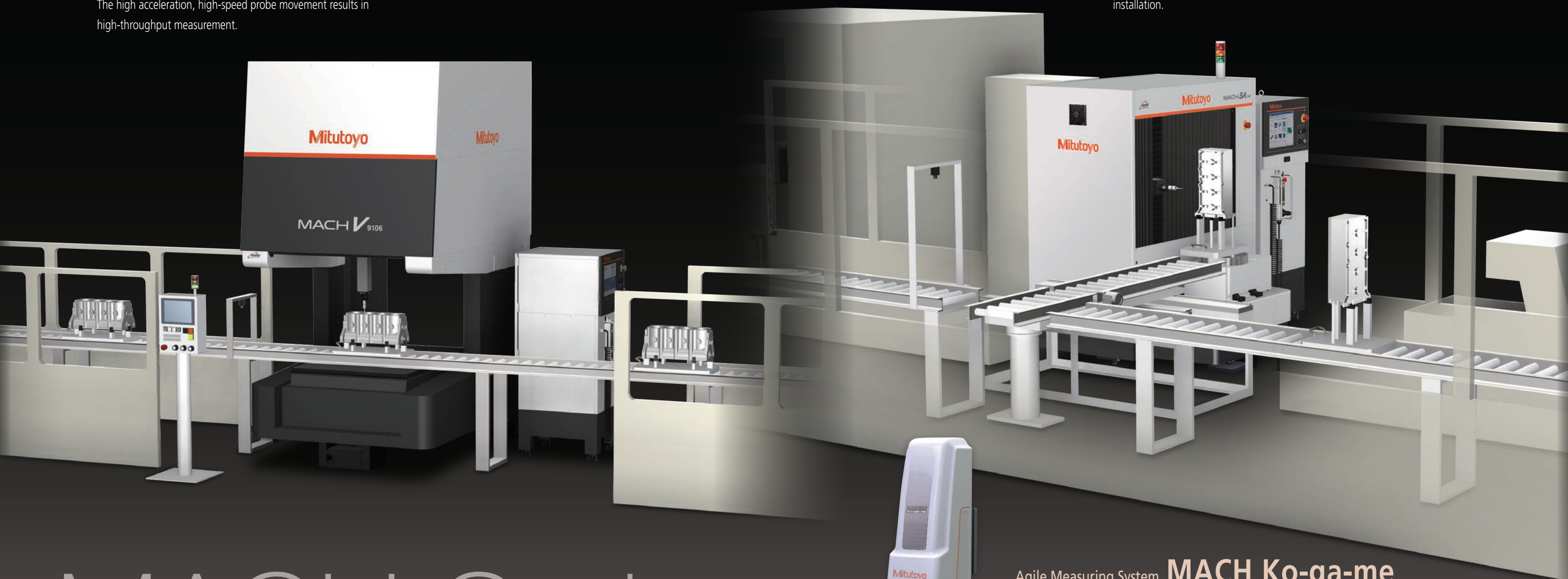

MACH Series



Agile Measuring System MACH Ko-ga-me

MACH Ko-ga-me can be used in standalone applications or integrated into work cells.

- If required, the system can measure workpiece features that exceed the Ko-ga-me's X stroke by mounting the workpiece, or the Ko-ga-me, on an auxiliary X axis

SMART FACTORY

From status management to preventive maintenance.
Kickstart your smart factory through visualization.

Mitutoyo has developed new features that use a network to centrally manage manufacturing process information. The MeasurLink software package helps prevent defective parts by collecting and analyzing measurement data in real time. The Status Monitor (Smart Measuring System, or SMS), which indicates the operational status of the measuring machine; and the Condition Monitor, which indicates the physical condition of the machine itself, help maintain measurement accuracy, increase productivity, and improve maintenance management.



Status Monitor

Remote machine monitoring

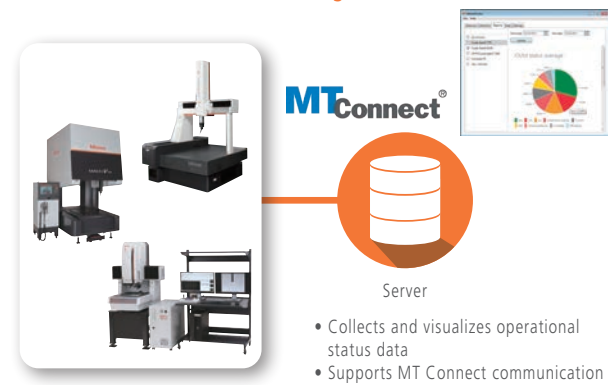

Condition Monitor

Conduct preventive maintenance through CMM status monitoring

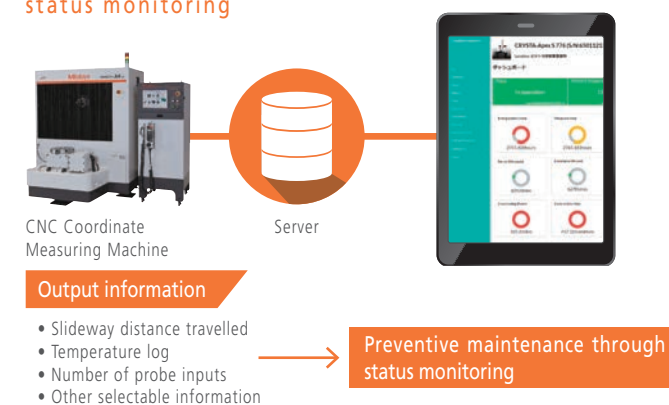

MeasurLink

Reduces defective products by visualizing quality

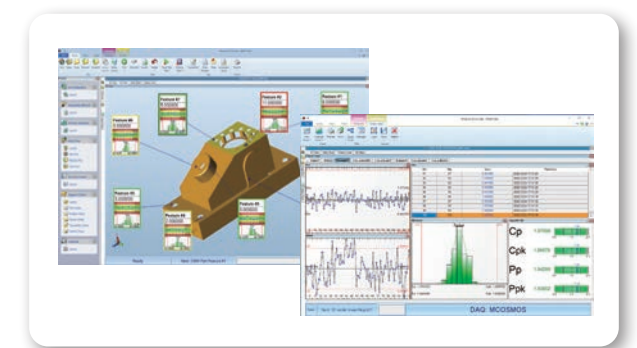

MACH-V

An Optimal and Flexible Measuring System in Place of Dedicated Gage Measurement in a Production Line.



High-speed drive up to a maximum of 866 mm/s

The vertical in-line coordinate measuring machine with excellent acceleration (8,770 mm/s²), measuring speed (at the moment of contact: 20 mm/s) as well as drive speed. This system contributes to the reduction in total cost as an auto-measurement system, either in a line or at line side where a reduction in measurement time is required, and can also serve as a dedicated machine or a substitute system for gages.

Space-saving design helps installation in a production line

In consideration of installation between processing machines, the width of this machine has been reduced by 15 % compared with its predecessor, thus contributing to a reduction in line length. Open access to the measuring area from the front/back and left/right has increased flexibility in the routing arrangements for a workpiece.

Accuracy assurance throughout a wide temperature range (5 to 35 °C)

Real-time thermal compensation applied to measurements and origin setting ensures excellent accuracy (referred to 20 °C) over a wide ambient temperature range. The graph below shows the effectiveness of the scheme in maintaining accuracy over a range of more than 30 °C.

Highly effective thermal compensation of the MACH-V9106

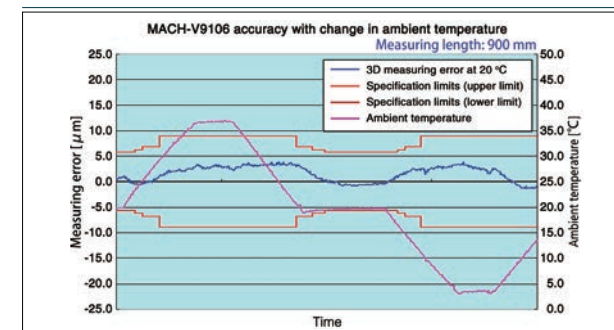

Improved dust resistance

This series has improved dust resistance by installing the drive system and scale units in a dust-tight enclosure at the upper part of the machine. The control unit and PC are installed in the dust-tight rack.

Improved ease of maintenance

The ease-of-maintenance construction and air-free operation means less chance of maintenance problems occurring.

Higher speed and accuracy with barycentric drive

When the components of a CMM slide are driven by a force offset from the combined mass center, a rotation-inducing torque is produced that is detrimental to accuracy. To prevent this torque generation, the MACH-V Series employs the barycentric drive system, achieving an ideal drive that minimizes slide rotation, especially under high drive acceleration conditions, by applying the drive force directly through the mass center of the slide.

This technique enables high-speed measurement with minimum accuracy deterioration compared with commonly-used CMMs.

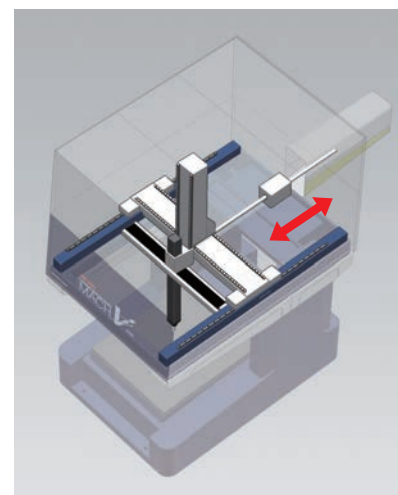

Workpiece thermal compensation essential for in-line measurement

Generally, during production, the temperature of a workpiece differs from that of the measuring machine due to processing and washing and is always changing.

To support in-line operations, the machine must continue accurate measurement (referred to 20 °C) even while the size of a workpiece is changing due to this temperature difference.

The following graph shows the high degree of compensation resulting when a MACH-V Series machine (at 20 °C) measured a certain workpiece while it cooled from 40 °C towards 20 °C. The thermal compensation function takes into account the change in size due to work-piece temperature.

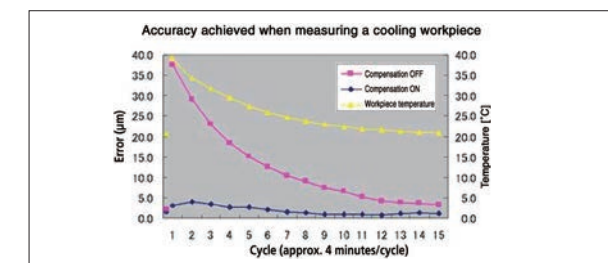

External Dimensions

(Unit: mm)

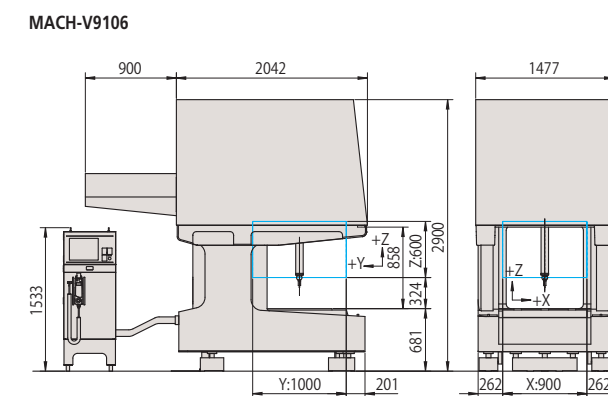

Specifications

Item	Model	MACH-V9106
Measuring range	X axis	900 mm
	Y axis	1000 mm
	Z axis	600 mm
Resolution		0.0001 mm (0.1 µm)
Guide system		Linear guide on each axis
Operating speeds	CNC Mode	Drive speed: each axis 8 to 500 mm/s; Max. combined speed 866 mm/s
		1 to 20 mm/s (Measuring speed)
	Joystick mode	0 to 80 mm/s (High Speed)
Maximum drive acceleration		0.05 mm/s ² (Fine Speed)
		Each axis 5063 mm/s ² ; Max. combined acceleration 8770 mm/s ²
Scale type		Linear encoder
Workpiece	Maximum height	800 mm
	Maximum mass	150 kg
Mass of machine (including the mounting stand and controller)		4130 kg

Operating environment

		Temperature
Accuracy assurance conditions	Temperature range	5 to 35 °C
	Temperature variation	2 °C or less per hour 10 °C or less per 24 hours
	Temperature gradient	Vertical: 1 °C or less per meter Horizontal: 1 °C or less per meter

Accuracy

Length measurement error ISO 10360-2: 2009

Probe used	Temperature range	Max. permissible length measurement error	Repeatability angle (R ₀ , MPE)
SP25M (stylus: ø4x50 mm)	19 to 21 °C	E ₀ , MPE=2.5 + 3.5L/1000 µm E ₁₅₀ , MPE=2.5 + 3.5L/1000 µm	2.2
	18 to 22 °C	E ₀ , MPE=2.7 + 3.8L/1000 µm E ₁₅₀ , MPE=2.7 + 3.8L/1000 µm	
	15 to 25 °C	E ₀ , MPE=2.9 + 4.3L/1000 µm E ₁₅₀ , MPE=2.9 + 4.3L/1000 µm	
	5 to 35 °C	E ₀ , MPE=3.6 + 5.8L/1000 µm E ₁₅₀ , MPE=3.6 + 5.8L/1000 µm	
TP7M (stylus: ø4x18 mm)	19 to 21 °C	E ₀ , MPE=2.5 + 3.5L/1000 µm	2.5
	18 to 22 °C	E ₀ , MPE=2.7 + 3.8L/1000 µm	
	15 to 25 °C	E ₀ , MPE=2.9 + 4.3L/1000 µm	
	5 to 35 °C	E ₀ , MPE=3.6 + 5.8L/1000 µm	

Single stylus form error ISO 10360-5: 2010

Probe used	Max. permissible single stylus form error (P _{FTU} , MPE)
SP25M (stylus: ø4x50 mm)	2.2
TP7M (stylus: ø4x18 mm)	2.5

Scanning accuracy ISO 10360-4: 2000

Applied probe	Maximum permissible error (scanning mode) (MPE _{THP})
SP25M (stylus: ø4x50 mm)	4.0

MACH-3A

Long-awaited Horizontal Coordinate Measuring System Appropriate for a Horizontal Machining Line.



High-speed drive up to a maximum of 1,212 mm/s

The horizontal in-line coordinate measuring machine with excellent acceleration (11,882 mm/s²) and measuring speed (at the moment of contact: 30 mm/s) as well as drive speed. This system contributes to the reduction in total cost as an auto auto-measurement system, either in a line or at line side where a reduction in measurement time is required, and can also serve as a dedicated machine or a substitute system for gages.

Space-saving design helps installation in a production line

This series comprises horizontal coordinate measuring machines intended for installation between processing machines. The horizontal-axis design allows this system to use the same workpiece handling and routing as the processing machines use.

Accuracy assurance throughout a wide temperature range (5 to 40 °C)

Real-time thermal compensation applied to measurements and origin-setting assure excellent accuracy (referred to 20 °C) over a much wider range of temperature than conventional CMMs. The graph below shows the effectiveness of the scheme.

Highly effective thermal compensation of the MACH-3A 653

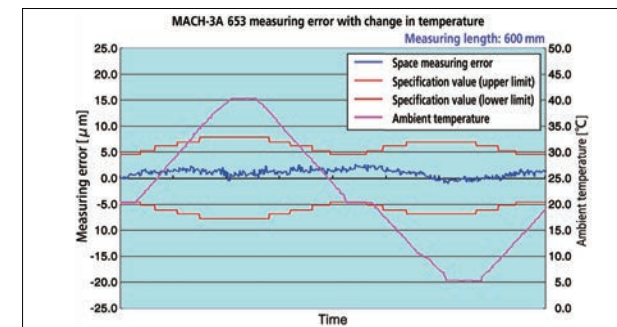

Improved dust resistance

This system incorporates a control unit and a PC for measurement and has attained superior durability through a design targeted on 24-hour operation.

Improved ease of maintenance

The ease-of-maintenance construction and air-free operation means less chance of maintenance problems occurring.

Extremely high throughput

The table below shows a comparison of transmission case measurements between a standard coordinate measuring machine (CRYSTA-Apex V Series) and in-line coordinate measuring machines (MACH-V9106 and MACH-3A653). The throughput of MACH-V and MACH-3A is extremely high.

Measurement items: True position (4 points), ID (5 points), hole-to-hole pitch (3 points)

	CRYSTA Apex V Series	MACH-V9106	MACH-3A653
Maximum drive speed [mm/s]	519	866	1212
Maximum measuring speed [mm/s]	8	20	30
Maximum acceleration [m/s ²]	2.3	8.4	11.8
Measurement time [sec]	57.6	28.5	24.3

Note: Measurement time varies depending on the measurement conditions.

Workpiece thermal compensation essential for in-line measurement

The MACH-3A Series is provided with the same thermal compensation functions as the MACH-V Series.

For detailed information, refer to page 7.

Introduction to MACH-3A 483



- This is a high speed, versatile, shaft-measuring machine* appropriate for production line use.
 - Dedicated gages cost a great deal of money for every design change to a workpiece. This measuring machine provides an economical alternative by accommodating such changes just by an easy edit of a part program, allowing dramatic cost-reduction to be achieved.
 - This single machine enables fast and accurate measurement of all evaluation items on a crankshaft or camshaft.
- * This is a custom-order product.

External Dimensions

(Unit: mm)

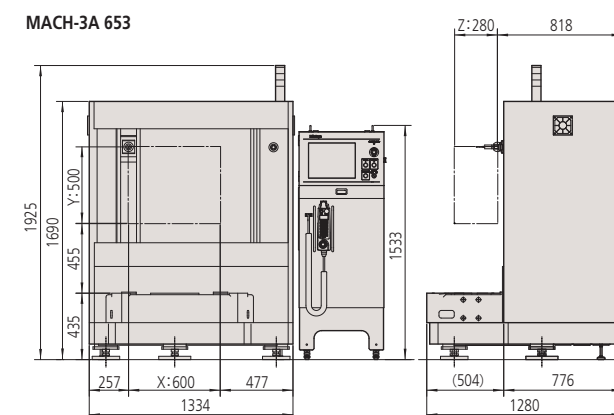

Specifications

Item	Model	MACH-3A 653
Measuring range	X axis	600 mm
	Y axis	500 mm
	Z axis	280 mm
Resolution		0.0001 mm (0.1 µm)
Guide system		Linear guide on each axis
Operating speeds	CNC Mode	Drive speed: each axis 8 to 700 mm/s; Max. combined speed 1212 mm/s
		1 to 30 mm/s (Measuring speed for TP7M) 1 to 20 mm/s (Measuring speed for TP20)
	Joystick mode	0 to 80 mm/s (High Speed) 0 to 3 mm/s (Low Speed) 0.05 mm/s (Fine Speed)
Maximum drive acceleration		Each axis 6860 mm/s ² ; Max. combined acceleration 11882 mm/s ²
Scale type		Linear encoder
Workpiece	Maximum mass	200 kg
Mass of machine (including the controller)		1400 kg (excluding optional accessories)

Operating environment

		Temperature
Accuracy assurance conditions	Temperature range	5 to 40 °C
	Temperature variation	2 °C or less per hour 10 °C or less per 24 hours
	Temperature gradient	Vertical: 1 °C or less per meter Horizontal: 1 °C or less per meter

Accuracy ISO 10360-2: 2009

unit: µm

Probe used	Maximum permissible error of measurement (MPE _v)	Maximum permissible error of probing (MPE _p)
SP25M (stylus: ø4×50 mm)	2.2 + 3.5L/1000 (19 to 21 °C)	2.2
	2.5 + 4.2L/1000 (15 to 25 °C)	
	2.9 + 5.0L/1000 (10 to 30 °C)	
	3.2 + 5.7L/1000 (5 to 35 °C)	
TP7M (stylus: ø4×20 mm)	3.6 + 6.5L/1000 (5 to 40 °C)	2.5
	2.5 + 3.5L/1000 (19 to 21 °C)	
	2.8 + 4.2L/1000 (15 to 25 °C)	
	3.2 + 5.0L/1000 (10 to 30 °C)	
TP20 (stylus: ø3×10 mm)	3.5 + 5.7L/1000 (5 to 35 °C)	2.7
	3.9 + 6.5L/1000 (5 to 40 °C)	
	2.7 + 3.5L/1000 (19 to 21 °C)	
	3.0 + 4.2L/1000 (15 to 25 °C)	
	3.4 + 5.0L/1000 (10 to 30 °C)	
	3.7 + 5.7L/1000 (5 to 35 °C)	
	4.1 + 6.5L/1000 (5 to 40 °C)	

Note 1: L= Arbitrary measuring length (unit: mm)

Note 2: The index table is optional.

Scanning accuracy ISO 10360-4: 2000

unit: µm

Probe used	Maximum permissible error (scanning mode) (MPE _{sc})
SP25M (stylus: ø4×50 mm)	3.8

MACH Ko-ga-me

A fast, highly accurate and flexible CNC measuring head

- Can be used in standalone applications or integrated into work cells.
- The head can be used as a compact CNC measuring machine when mounted on a special stand. It can also expand the measurement range when mounted on a single- or multi-axis machine.
- The dust-proof head does not require air.
- The head allows you to configure a measurement system that can meet the specific needs of the processing environment to improve measurement efficiency.
- The built-in temperature correction function ensures accuracy under a wide temperature range of 10 to 35 °C.



Standalone system



*1 The stand is option.

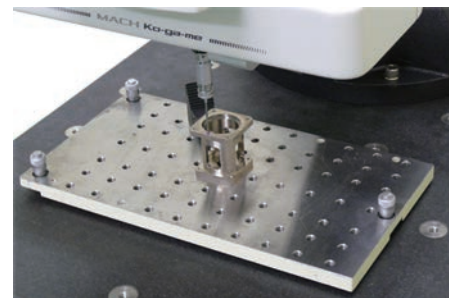

High speed measurement for a small workpiece

Example of measuring a large workpiece: When mounted on another machine

Example of moving-head system



Auxiliary X axis system*2

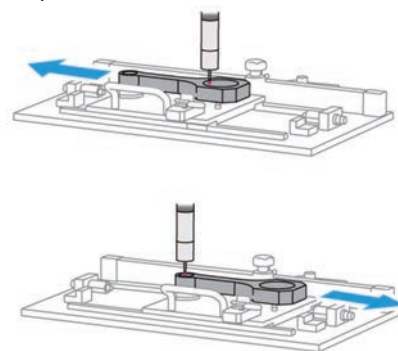

*2 An auxiliary X-axis system shall be provided by the customer.

Specifications

Item	Model	KGM12128-C
Measuring range	X axis	120 mm
	Y axis	120 mm
	Z axis	80 mm
Resolution		0.00002 mm (0.02 μm)
Operating speeds	CNC Mode (AUTO)	Drive speed: each axis 8 to 200 mm/s; Max. combined speed 340 mm/s
		1 to 15 mm/s (Measuring speed)
	CNC Mode (MANUAL)	Drive speed: each axis 8 to 200 mm/s; Max. combined speed 250 mm/s
		1 to 15 mm/s (Measuring speed)
Joystick mode		0 to 80 mm/s (High Speed)
		0 to 15 mm/s (Low Speed)
		0.05 mm/s (Fine Speed)
Maximum drive acceleration		Each axis 3900 mm/s ² ; Max. combined acceleration 6750 mm/s ²
Guide system		Direct-acting hard bearing
Drive method		DC motor+ball screw (Speed/position feedback)
Scale type		Linear encoder

Operating environment

		Temperature
Accuracy assurance conditions	Temperature range	10 to 35 °C
	Temperature variation	2 °C or less per hour
		10 °C or less per 24 hours
Temperature gradient	1 °C or less per meter (Both vertically and horizontally)	

Accuracy

Length measurement error ISO 10360-2: 2009				unit: μm
Probe used	Temperature range	Max. permissible length measurement error (E _{0, MPE})	Repeatability range (R _{0, MPE})	
TP200 (stylus: ø3×10 mm)	19 to 21 °C	2.4 + 5.7L/1000 μm	1.9	
	15 to 25 °C	2.7 + 6.4L/1000 μm		
	10 to 30 °C	3.1 + 7.2L/1000 μm		
	10 to 35 °C	3.4 + 7.9L/1000 μm		
SP25M (stylus: ø4×50 mm)	19 to 21 °C	2.4 + 5.7L/1000 μm	1.3	
	15 to 25 °C	2.7 + 6.4L/1000 μm		
	10 to 30 °C	3.1 + 7.2L/1000 μm		
	10 to 35 °C	3.4 + 7.9L/1000 μm		

Single stylus form error ISO 10360-5: 2010

unit: μm	
Probe used	Max. permissible single stylus form error (P _{TV} , MPE)
TP200 (stylus: ø3×10 mm)	2.2
SP25M (stylus: ø4×50 mm)	2.2

Scanning accuracy ISO 10360-4: 2000

unit: μm	
Applied probe	Maximum permissible error (scanning mode) (MPE _{TM})
SP25M (stylus: ø4×50 mm)	2.7 (30 s)

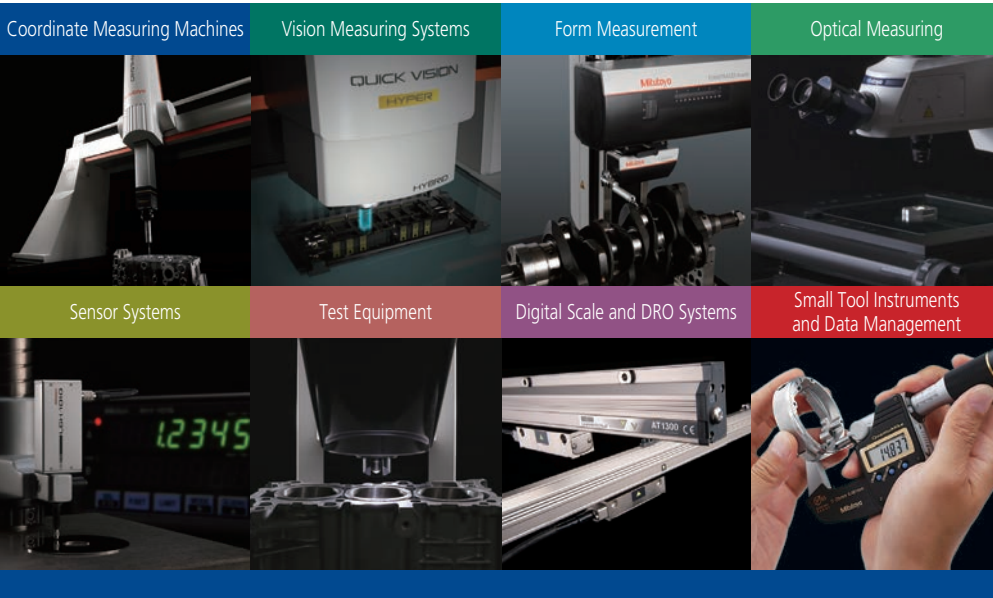

Whatever your challenges are, Mitutoyo supports you from start to finish.

Mitutoyo is not only a manufacturer of top quality measuring products but one that also offers qualified support for the lifetime of the equipment, backed up by comprehensive services that ensure your staff can make the very best use of the investment.

Apart from the basics of calibration and repair, Mitutoyo offers product and metrology training, as well as IT support for the sophisticated software used in modern measuring technology. We can also design, build, test and deliver measuring solutions and even, if deemed cost-effective, take your critical measurement challenges in-house on a sub-contract basis.



Find additional product literature
and our product catalogue

<https://www.mitutoyo.co.jp/global.html>

Our products are classified as regulated items under Japanese Foreign Exchange and Foreign Trade Law. Please consult us in advance if you wish to export our products to any other country. If the purchased product is exported, even though it is not a regulated item (Catch-All controls item), the customer service available for that product may be affected. If you have any questions, please consult your local Mitutoyo sales office.

Note: Product illustrations are without obligation. Product descriptions, in particular any and all technical specifications, are only binding when explicitly agreed upon. MITUTOYO and MICAT are either registered trademarks or trademarks of Mitutoyo Corp. in Japan and/or other countries/regions. Other product, company and brand names mentioned herein are for identification purposes only and may be the trademarks of their respective holders.

Mitutoyo

Mitutoyo Corporation

20-1, Sakado 1-Chome,
Takatsu-ku, Kawasaki-shi,
Kanagawa 213-8533, Japan
T +81 (0) 44 813-8230
F +81 (0) 44 813-8231
<https://www.mitutoyo.co.jp>