

Rockwell Hardness Testing Machines HR-200/300/400 Series



Rockwell hardness testing machine series Versatile smart models

4 models to suit practically every application



HR-210MR

Rockwell hardness testing machine

Manually handles test force and preliminary test force selection. Motor drive controls loading sequence.
Preliminary test force (handling support): Automatic pre-setting dial gage



HR-320MS

Dual type (Rockwell/Rockwell superficial) hardness testing machine

Manually handles test force and preliminary test force selection. Motor drive controls loading sequence.
Preliminary test force (handling support): Loading navigator indication



HR-430MR

Rockwell hardness testing machine

Smart type, but equipped with switching power steering and automatic brake handle for auto start feature. Motor drive controls loading sequence.



HR-430MS

Dual type (Rockwell/Rockwell superficial combined use) hardness test equipment

Smart type, but equipped with switching power steering and automatic brake handle for auto start feature. Motor drive controls loading sequence.

Features

The newly designed frame provides maximum clearance for positioning the workpiece. A flat table is all that is needed for mounting these testing machines.

Simple to operate

With analogue type (HR-210MR), the gauge presetting operation is unnecessary by the adoption of an automatic presetting dial gauge.



The digital type (HR-430MR and HR-430MS), with the adoption of the automatic brake handle and load sequence, with only simple handling test possibility.



The digital type (HR-320MS, HR-430MR and HR-430MS) has digimatic output and our Digimatic Mini-Processor (DP-1VA LOGGER) to print and input tools (USB-ITN-E) to connect to a PC and use for data transfer.



Supports Brinell hardness tests. Brinell hardness tests can be performed using the optional Brinell weight set and ball indenter. The microscope used for measurement must be prepared by the user.

Specifications

	HR-210MR	HR-320MS	HR-430MR	HR-430MS
Type of hardness test	Rockwell			
Preliminary test force (N)	98.07	Rockwell superficial 29.42 98.07	98.07	Rockwell superficial 29.42 98.07
Total test force (N)	Superficial —	147.1 294.2 441.3	—	147.1 294.2 441.3
	Rockwell	588.4 980.7 1471		
Standard	JIS B 7726 ISO6508-2	JIS B 7726 ISO6508-2 ASTM E18-24		
Preliminary test force switching	—	Switchable with the preliminary test force switch knob	—	Switchable with the preliminary test force switch knob
Total test force switching mechanism	None (manual loading)		With the weight switch knob	
Loading mechanism	Motor load drive			
Retention duration setting	Fixed (total test force loading time: 3 to 5.5 s) / Manual (switchable with the switch)	Automatic: 1 to 99 s (can be set in 1 s increments) / Manual (switchable using a setting change)		
Up/down mechanism	Manual (handle)		Manual (handle) (automatic start at the test start position)	
Maximum height of the specimen	0 mm–100 mm (with bellows when using a flat anvil) 0 mm–180 mm (without bellows when using a flat anvil)			
Depth of the specimen	165 mm (from the center of the indenter shaft)			
Display	Analog (dial gage)	Digital (matrix LCD with backlight)		
Minimum display unit	0.5 HR	0.1 HR		
Function	GO/NG judgment			
	Offset setting			
	Hardness conversion			
Data output	Digimatic RS-232C			
Power supply	AC Input : 100-240 V, 50-60 Hz, 1.8 A, DC Output: 12 V – 4.17 A			
Dimensions	214 (W) × 512 (D) × 780 (H) mm			
Mass	Approximately 47 kg	Approximately 47 kg	Approximately 50 kg	

Note1: Plastic tests may not be supported depending on the plastic material.
 Note2: Brinell hardness tests can be performed by using a Brinell weight set, Brinell indenter, and a measurement microscope.
 Note3: The testing machines are supplied without indenters. Please prepare optional indenters.

Standard accessories

Code No.	Item	Specifications
810-039	Flat anvil	ø64 mm
810-040	V-anvil (large)	ø40 mm, 120 ° V-groove width 30 mm
357651	AC adapter	—

Code No.	Item	Specifications
—	User's manual	(Depends on the model)
—	Accessory box	—
11B8941	Level	—

External dimensions

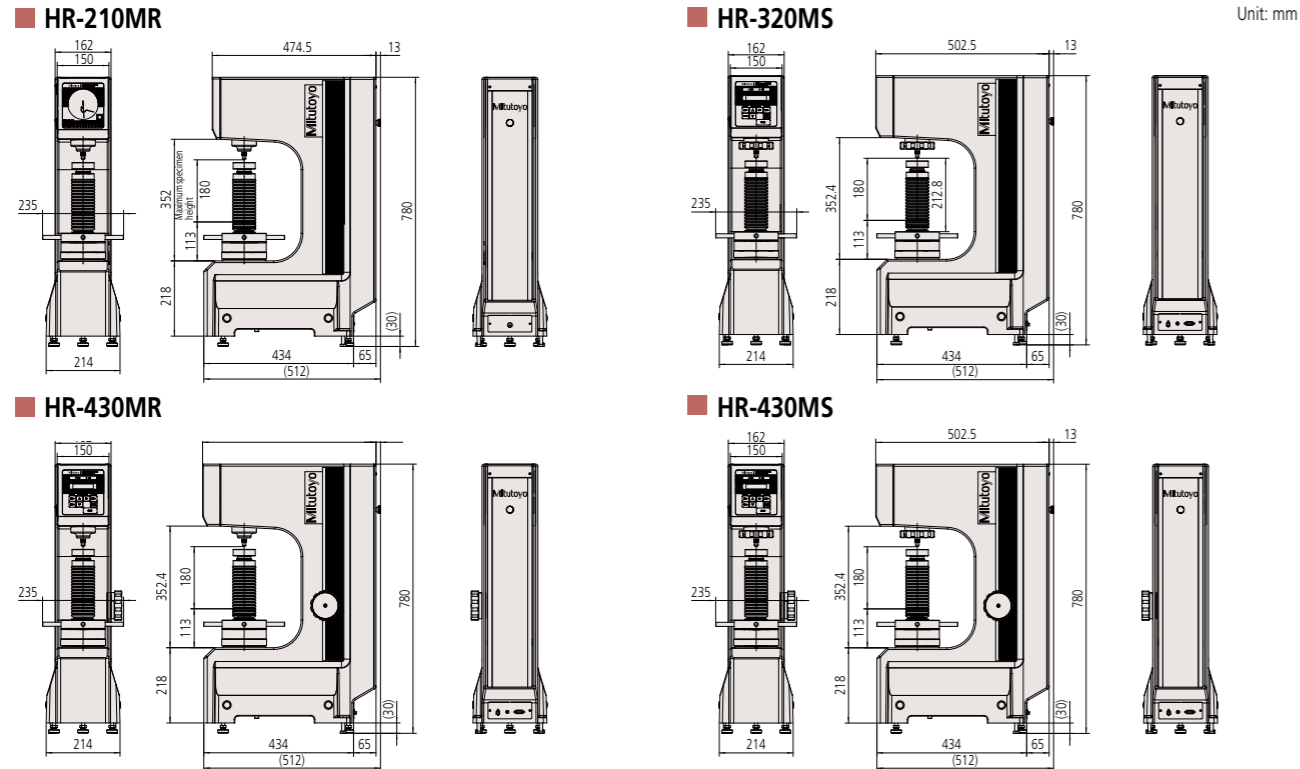

Optional accessories

Indenters for Rockwell hardness testing

Code No.	Item	JIS	JIS/ISO	ASTM/ISO	Remark
19BAA072	Diamond indenter	○	○		Compliant with ISO/JIS standards, only for Rockwell hardness tests
19BAA073	Diamond indenter	●	●		Compliant with ISO/JIS standards, also for superficial hardness tests
11AAD461	ø1/16" Steel ball indenter	○			Compliant with JIS standards
11AAD462	ø1/8" Steel ball indenter	○			
11AAD463	ø1/4" Steel ball indenter	○			
11AAD464	ø1/2" Steel ball indenter	○			
11AAD465	ø1/16" Carbide ball indenter		○		Compliant with ISO standards
11AAD466	ø1/8" Carbide ball indenter		○		
11AAD467	ø1/4" Carbide ball indenter		○		
11AAD468	ø1/2" Carbide ball indenter		○		
11AAE318	Rockwell diamond indenter ASTM			○	Compliant with ASTM/ISO standards With class B calibration certificate and inspection certificate
11AAE319	ø1/16" Carbide ball indenter ASTM			○	
11AAE320	ø1/8" Carbide ball indenter ASTM			○	
11AAE321	ø1/4" Carbide ball indenter ASTM			○	
11AAE322	ø1/2" Carbide ball indenter ASTM			○	

Note1: ● indicates indenters for HR-320MS and HR-430MS.
 Note2: Indenters compliant with ASTM/ISO standards are for HR-320MS, HR-430MR, and HR-430MS.

Spare ball for indenters

Code No.	Item	Remark
19BAA082	ø1/16" Steel ball (spare)	10 pcs./set
19BAA083	ø1/8" Steel ball (spare)	
19BAA084	ø1/4" Steel ball (spare)	
19BAA085	ø1/2" Steel ball (spare)	
19BAA507	ø1/16" Spare carbide ball	1 pc./set
19BAA508	ø1/8" Spare carbide ball	
19BAA509	ø1/4" Spare carbide ball	
19BAA510	ø1/2" Spare carbide ball	
11AAE323	ø1/16" Spare carbide ball ASTM	1 pc./set Compliant with ASTM/ISO standards With class B calibration certificate and inspection certificate
11AAE324	ø1/8" Spare carbide ball ASTM	
11AAE325	ø1/4" Spare carbide ball ASTM	
11AAE326	ø1/2" Spare carbide ball ASTM	

Specimen fixtures

Code No. 810-038
Round table ø250 mm

For large specimens

Code No. 810-037
Round table ø180 mm

For large specimens

Code No. 810-040
V anvil (large)
(ø40 mm, groove width 30 mm)
For shaft material (ø9 to 58 mm)

Code No. 810-043
Spot anvil
(ø12 mm)

Code No. 810-041
V anvil (small)
(ø40 mm, groove width 6 mm)
For shaft material (ø3 to 7 mm)

Code No. 810-044
Spot anvil
(ø5.5 mm)
For sheet specimens

Code No. 810-028-1
Jack rest

For testing long specimens using round table or anvil

Code No. 810-027
VARI-REST

For testing long specimens using anvil

Code No. 810-029
Special V anvil
(Length 400 mm, groove width 50 mm)
For shaft material (Max. ø100 mm)

Code No. 810-026
Fine adjustment table for Jominy test

JIS G 0561 For steel hardenability testing

Code No. 810-030
Diamond spot anvil
(ø10 mm)
For sheet specimens
*For Rockwell superficial hardness testing

Code No. 810-042
Small V anvil
(ø10 mm)
For shaft material (ø3 to 14 mm)

Code No. 810-048
Console table

Optional accessories

Hardness reference blocks

Code No.	Item	Remark
19BAA035	Hardness reference block 10HRC	Compliant with ISO/JIS standards With an inspection certificate from the standard block manufacturer.
19BAA036	Hardness reference block 20HRC	
19BAA037	Hardness reference block 30HRC	
19BAA038	Hardness reference block 40HRC	
19BAA039	Hardness reference block 50HRC	
19BAA040	Hardness reference block 60HRC	
19BAA041	Hardness reference block 70HRC	
19BAA042	Hardness reference block 41HR30N*	
19BAA043	Hardness reference block 50HR30N*	
19BAA044	Hardness reference block 60HR30N*	
19BAA045	Hardness reference block 73HR30N*	
19BAA046	Hardness reference block 83HR30N*	
19BAA047	Hardness reference block 75HR15N*	
19BAA048	Hardness reference block 85HR15N*	
19BAA049	Hardness reference block 90HR15N*	
11AAD474	Hardness reference block 32HRBW	
11AAD475	Hardness reference block 42HRBW	
11AAD476	Hardness reference block 52HRBW	
11AAD477	Hardness reference block 62HRBW	
11AAD478	Hardness reference block 72HRBW	
11AAD479	Hardness reference block 82HRBW	
11AAD480	Hardness reference block 90HRBW	
11AAD481	Hardness reference block 32HR30TW*	
11AAD482	Hardness reference block 42HR30TW*	
11AAD483	Hardness reference block 52HR30TW*	
11AAD484	Hardness reference block 62HR30TW*	
11AAD485	Hardness reference block 72HR30TW*	
11AAD486	Hardness reference block 78HR15TW*	
11AAD487	Hardness reference block 82HR15TW*	
11AAD488	Hardness reference block 87HR15TW*	
11AAD194	Hardness reference block 90HRES	To confirm operation with plastic tests.
11AAD195	Hardness reference block 90HREW	With an inspection certificate from the standard block manufacturer.
19BAA028	Hardness reference block 32HRBS	Compliant with JIS standards With an inspection certificate from the standard block manufacturer.
19BAA029	Hardness reference block 42HRBS	
19BAA030	Hardness reference block 52HRBS	
19BAA031	Hardness reference block 62HRBS	
19BAA032	Hardness reference block 72HRBS	
19BAA033	Hardness reference block 82HRBS	
19BAA034	Hardness reference block 90HRBS	
19BAA050	Hardness reference block 32HR30TS*	
19BAA051	Hardness reference block 42HR30TS*	
19BAA052	Hardness reference block 52HR30TS*	
19BAA053	Hardness reference block 62HR30TS*	
19BAA054	Hardness reference block 72HR30TS*	
19BAA055	Hardness reference block 78HR15TS*	
19BAA056	Hardness reference block 82HR15TS*	
19BAA057	Hardness reference block 87HR15TS*	

* Reference block for superficial hardness testing

Code No.	Item	Remark
11AAE327	Hardness reference block 30HRC ASTM	Compliant with ASTM/ISO standards With class B calibration certificate and inspection certificate
11AAE328	Hardness reference block 45HRC ASTM	
11AAE329	Hardness reference block 63HRC ASTM	
11AAE331	Hardness reference block 70HRBW ASTM	
11AAE332	Hardness reference block 90HRBW ASTM	
11AAE333	Hardness reference block 65HRA ASTM	
11AAE334	Hardness reference block 76HRA ASTM	
11AAE335	Hardness reference block 85HRA ASTM	
11AAE336	Hardness reference block 75HR15N ASTM*	
11AAE337	Hardness reference block 85HR15N ASTM*	
11AAE338	Hardness reference block 92HR15N ASTM*	
11AAE339	Hardness reference block 50HR30N ASTM*	
11AAE340	Hardness reference block 68HR30N ASTM*	
11AAE341	Hardness reference block 83HR30N ASTM*	
11AAE342	Hardness reference block 25HR45N ASTM*	
11AAE343	Hardness reference block 43HR45N ASTM*	
11AAE344	Hardness reference block 72HR45N ASTM*	
11AAE345	Hardness reference block 67HR15TW ASTM*	
11AAE346	Hardness reference block 83HR15TW ASTM*	
11AAE347	Hardness reference block 91HR15TW ASTM*	
11AAE348	Hardness reference block 36HR30TW ASTM*	
11AAE349	Hardness reference block 63HR30TW ASTM*	
11AAE350	Hardness reference block 76HR30TW ASTM*	
11AAE360	Hardness reference block 75HREW ASTM	
11AAE361	Hardness reference block 87HREW ASTM	
11AAE362	Hardness reference block 100HREW ASTM	

Optional accessories for Brinell testing (test conditions, weight set, indenter)

Hardness testing machine	Weight set Item	Carbide ball indenter for Brinell			
		11AAD469 ø1 mm Brinell indenter	11AAD470 ø2.5 mm Brinell indenter	11AAD471 ø5 mm Brinell indenter	11AAD472 ø10 mm Brinell indenter
HR-210MR	Brinell weight set 62.5 125 187.5	—	HBW2.5/62.5 HBW2.5/187.5	HBW5/62.5 HBW5/125	(HBW10/100 ^{*1})
HR-320MS	Brinell weight set 31.25 62.5 125 187.5	(HBW1/10 ^{*1}) (HBW1/30 ^{*1})	HBW2.5/31.25 HBW2.5/62.5 HBW2.5/187.5	HBW5/62.5 HBW5/125	(HBW10/100 ^{*1})
HR-430MR	Brinell weight set 62.5 125 187.5	—	HBW2.5/62.5 HBW2.5/187.5	HBW5/62.5 HBW5/125	(HBW10/100 ^{*1})
HR-430MS	Brinell weight set 31.25 62.5 125 187.5	(HBW1/10 ^{*1}) (HBW1/30 ^{*1})	HBW2.5/31.25 HBW2.5/62.5 HBW2.5/187.5	HBW5/62.5 HBW5/125	(HBW10/100 ^{*1})
		Spare Carbide ball for Brinell			
	Code No.	19BAA281	19BAA283	19BAA162	19BAA163
	Item	Spare carbide ball 1 mm	Spare carbide ball 2.5 mm	Spare carbide ball 5 mm	Spare carbide ball 10 mm
	Size (Quantity)	ø1 mm (1 pc.)	ø2.5 mm (1 pc.)	ø5 mm (1 pc.)	ø10 mm (1 pc.)

*1: The built-in weights are used for this range. Only an indenter needs to be purchased.

Options for data output * Cannot be used with HR-210.

Compact printer with data logger function Digimatic Mini-Processor DP-1VA LOGGER

- A compact printer for statistical calculation and printing data from hardness testing machines with Digimatic output function.
- High performance with support of measurement data printing, statistical calculation, histograms, and D chart creation, as well as complex calculations required for X-R control charts.
- Up to 1,000 data items can be saved in the machine using the data logger function. All data can be transferred in one operation by connecting the printer to a computer using a USB cable (sold separately).
- The connection cable to the hardness testing machine is not supplied. A connection cable sold separately is required.



Code No. 264-506*
DP-1VA LOGGER

Cables
Code No. 06AFZ050
USB cable (Type A - micro B)

Code No. 937387
Connection cable (1 m) Type E

Code No. 965013
Connection cable (2 m) Type E



* To denote your AC line voltage add the following suffixes. **A** for North America, **D** for Europe, **E** for UK, **K** for Korea, **DC** for China, and no suffix is required for Japan.

Measurement data wireless communication system U-WAVE

- Used to import data from hardness testing machines with Digimatic output function to a computer using wireless communication.
- Easy installation without cables that may get in the way thanks to wireless communication (up to 20 m).
- Data can be imported to common software with keyboard input (Excel, notepad, etc.) using the data interface function of the software supplied with U-WAVE-R.
- Test results from several hardness testing machines can be imported to a single computer using simultaneous transfers from multiple U-WAVE devices.



Code No. 02AZD810D
U-WAVE-R
With USB 2.0 cable (1 m)



Code No. 02AZD880G
U-WAVE-T



U-WAVE-T connection cable
Code No. 02AZD790E
U-WAVE-T dedicated connection cable Type E

Digimatic Gage/PC Data Input Device USB Input Tool

- Interface used to export calculation results to spreadsheet software on a computer via a USB cable. Calculation results (values) can be exported in one operation.



USB Direct Input Tool
Code No. 06AFM380E
USB-ITN-E



USB keyboard signal converter type*
Code No. 264-020
IT-020U
* One of the cables below (sold separately) is required to connect the testing machine to the IT-020U.
1 m: Code No. 937387
2 m: Code No. 965013



Whatever your challenges are, Mitutoyo supports you from start to finish.

Mitutoyo is not only a manufacturer of top quality measuring products but one that also offers qualified support for the lifetime of the equipment, backed up by comprehensive services that ensure your staff can make the very best use of the investment.

Apart from the basics of calibration and repair, Mitutoyo offers product and metrology training, as well as IT support for the sophisticated software used in modern measuring technology. We can also design, build, test and deliver measuring solutions and even, if deemed cost-effective, take your critical measurement challenges in-house on a sub-contract basis.



Find additional product literature and our product catalog

<https://www.mitutoyo.co.jp/global.html>

Notes on Export Regulations:

Do not commit an act, which could directly or indirectly, violate any law or regulation of Japan, your country or any other international treaty, relating to the export or re-export of any commodities.

Mitutoyo products are designed, manufactured and sold as industrial products that are intended for use at manufacturing sites. Mitutoyo reserves the right to change any or all aspects of any product specification, including prices, designs and service content, without notice.

Our product names, service names and logomarks used on this brochure are trademarks of Mitutoyo Corporation in Japan and other countries. Other product names and service names etc. may be trademarks or registered trademarks of their respective companies. All product information contained in this brochure is current as of August 2025.

Mitutoyo

Mitutoyo Corporation

20-1, Sakado 1-Chome,
Takatsu-ku, Kawasaki-shi,
Kanagawa 213-8533, Japan
<https://www.mitutoyo.co.jp>