

## Rebound-Type Portable Hardness Tester **Pocket Vick** HH-V400

Test Equipment



Easy for Anyone, with One Press of a Button

# Instantly Test Hardness Anywhere, Anytime

The HH-V400 is a rebound-type hardness tester for metals. Hardness is determined from the ratio of the impact hammer's rebound velocity to its impact velocity.

Simply Set and Press the Button!

**POINT 1** Portable, One-click Device

**POINT 2** Wide Range of Test Targets

**POINT 3** Selectable Hardness Scale



For hardness testing of all metals, including large structures.

Note: Photograph is for illustrative purposes only. In an actual test, be sure to firmly hold the coil holder at the bottom of the detector.

Greatly improved functionality and operability, including color LCD display and enhanced statistical calculation functions

## Fully Redesigned Calculation Display

Clearer

Simpler

More User-friendly

**NEW**

**Color LCD**

- Backlit
- Eco mode function
- Auto off

**Easy-Operation Keys**

Easy-to-understand icons

- ⏻ Power on/off
- ⚙️ Menu screen display
- ✓ Confirm
- ⬅️ Back (return to previous screen)
- 📄 Data output
- ⬅️➡️ Change items and values



**SPC Connector**

- Data output

**USB Connector**

- Data output, charging

**Rechargeable Battery**

- Continuous operation for 8 hours

**External Output Devices (Optional)**

You can enter test data into Excel, Notepad, etc.



For printing out test data.



Test data can be output wirelessly and processed on a PC.



# NEW Key Points of the Calculation Display Unit

- Can automatically save up to 1800 test results
- Can register up to 100 samples
- Includes acceptance judgment, offsetting, and statistical calculation functions
- Convenient external output function



**Easy and convenient test setup with easy-to-understand operation key icons**  
Includes useful functions such as acceptance judgment, offsetting, and statistical calculation

### Sample Material Selection

Select the sample material from the material table.  
Example) A-1: Iron and steel

### Offset Value

Set the offset value.



### Acceptance Judgment

Set upper and lower limits.

### Statistical Calculation

Set the number of test repetitions (N) and perform statistical calculations.

### Test Results

### Statistical Calculation Results

### Offset Icon

The offset value is reflected in the test results.

### Test Scale

Example) HLD: Leeb hardness



You can switch between various test scales.

### Acceptance Judgment

Ave (average value)  
Max (maximum value)  
Min (minimum value)  
R (range [variance])  
SD (standard deviation) are calculated.

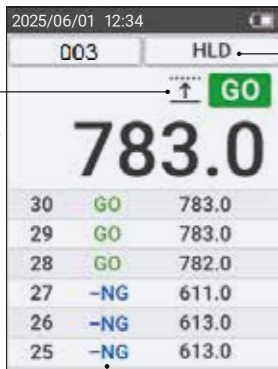

### Acceptance Judgment

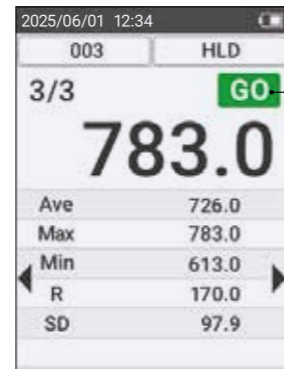

## Toggle the test results display between items

Easy display of test results and data management

### Test Number Display

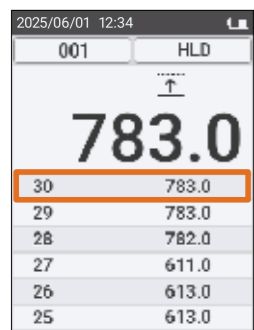

### Date Display

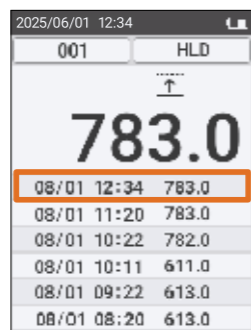

### Sample Display

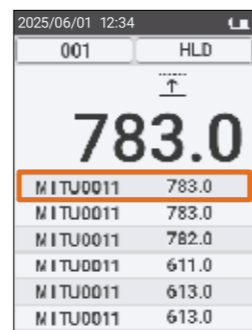

Register up to 100 samples.

# POINT Key Points of the Product

## 1. Portable, One-click Device

The HH-V400 is cordless with a rechargeable battery for portability and simple on-site testing. The tester can also be used for objects that cannot be placed onto a tabletop testing machine or that are not easily accessible.



When you want to do on-site measurement...



Simply press the detector against the sample surface and press the push button. No adjustment work is required when connecting the detector.

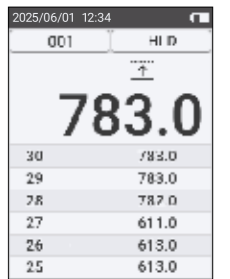
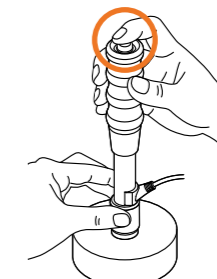
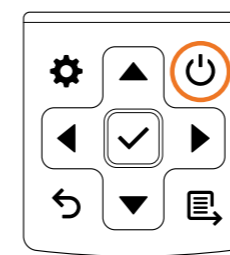

- (1) Turn the power on.
- (2) Select the material.
- (3) Press the push button.
- (4) The results are displayed.

### Material Table Selection

Screen display	Sample material
A-1	Iron and steel
A-2	Alloyed tool-steel
A-3	Gray iron

Screen display	Sample material
A-4	Spherical graphite cast iron
A-5	Stainless steel
A-6	Tool steels for cold-work

Screen display	Sample material
B-1	Brass
B-2	Casting copper-based alloys
B-3	Casting aluminum-based alloys
B-4	Copper-tin-based alloys

The automatic angle-correcting function allows testing in all directions, not just vertically.



Watch a video demonstration of simple omnidirectional measurement.



# POINT Key Points of the Product

## 2. Wide Range of Test Targets

In addition to general-purpose detectors, we offer a wide range of detectors to suit a variety of test subjects.

**Standard Detector**  
Standard-type general-purpose detector

**Detector D**  
(Standard type)



\*Standard accessory for HH-V400

**Detector DC**  
(Compact type)

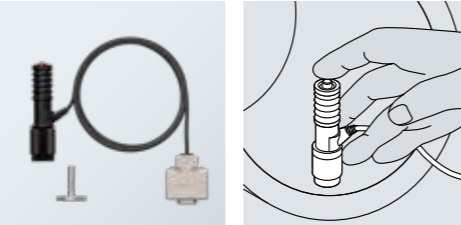

For narrow spaces such as the insides of pipes

**Optional Detector**  
Automatic recognition of detectors when changing them

**Detector D + 15**  
(15 mm longer than standard)

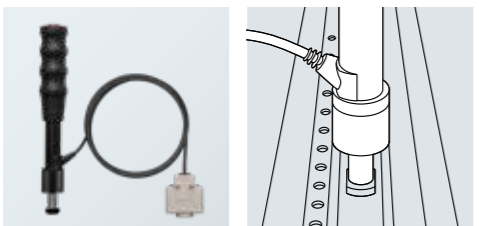

For gaps, grooves, and parts with shallow steps

**Detector DL**  
(For deep grooves)

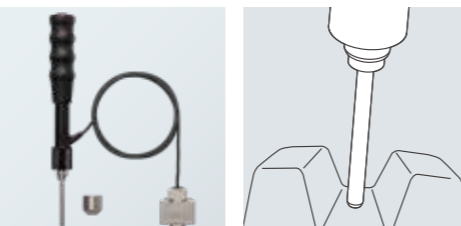

For narrow surfaces such as grooves between gear teeth

### Specifications

<b>Code No.</b>	<b>810-306</b>
<b>Model No.</b>	<b>HH-V400</b>
<b>Testing hardness and range</b>	Leeb hardness: 100.0 to 999.9 HLD
<b>Testing direction</b>	Omnidirectional (with automatic angle-correcting function)
<b>Hardness scale conversion function*</b> (Conversion range varies depending on material.)	Vickers hardness: 43 to 950 HV Brinell hardness: 20 to 655 HB Rockwell hardness (C-scale): 19.3 to 68.2 HRC Rockwell hardness (B-scale): 13.5 to 101.7 HRB Shore hardness: 30.1 to 99.5 HS (ASTM) 13.2 to 98.6 HS (JIS) Tensile strength: 390 to 1999 MPa Minimum thickness: 5 mm Minimum mass: 5 kg
<b>Sample conditions</b>	Testing position: At least 5 mm from the edge of the sample and at least 3 mm between test points Surface roughness: Ra 2.0 or less
<b>Functions</b>	Automatic angle correction, offset setting, acceptance judgment, hardness scale conversion, data memory storage (1800 points), statistical calculation function, eco mode, auto power-off, backlight
<b>Detector</b>	<b>Type</b> Detector D (standard type), impact hammer, with carbide ball at the tip
<b>Dimensions</b>	<b>Detector</b> ø28 x 175 mm (excluding cable)
	<b>Mass</b> Approx. 150 g
<b>Display unit</b>	<b>Screen</b> 2.83" (240 x 320 pixels), RGB color LCD
	<b>Dimensions</b> 174 x 68 x 32 mm <b>Mass</b> Approx. 250 g
<b>Power supply</b>	AC adapter, built-in battery (Ni-MH) (Up to 8 hours of operation after 100 minutes of charging)

\*HH-V400 guarantees the indicated values based on Leeb hardness. Converted values are for reference only.

### Standard Accessories

Code No.	Product Name	Quantity	Notes
—	Display unit	1	
—	Detector	1	Detector D (standard type)
—	Impact hammer	1	Uses a carbide ball at the tip.
12BAS450	AC adapter	1	Input voltage: AC100 V to 240 V ±10% (50 Hz/60 Hz) Output rating: DC 5.0 V 2.0 A Number of pins: 6
12BAS451	USB 2.0 cable	1	Type A-C
11BAB687	Handle	2	Ball-replacement tool
11AAA857	Small support ring	1	ø14 mm
05CAA952	Phillips screwdriver	1	For detector replacement
11PAA429	Storage box	1	
99MBG538B	Quick start guide	1	Japanese/English
99MBG537A	Instruction manual	1	English
—	Certificate of inspection	1	
—	Warranty	1	

\*Delivered in storage box.

### Options

Order No.	Product Name	Specifications
11AAE902	Detector D	ø28 × 174.5 mm (tip diameter ø22 mm)
11AAE903	Detector DC	ø18 × 86 mm (tip diameter ø22 mm)
11AAE904	Detector D +15	ø28 × 189.5 mm (tip width 12 mm)
11AAE905	Detector DL	ø28 × 229 mm (tip diameter ø4 mm)
11AAD241	Hardness reference block	880 HLD
11AAD242	Hardness reference block	830 HLD
11AAD243	Hardness reference block	730 HLD
11AAD244	Hardness reference block	630 HLD
11AAD245	Hardness reference block	520 HLD
11AAD240	Hardness test block	Approx. 800 HLD
19BAA248	Support ring	For convex cylindrical surfaces (R10 to 20 mm): for Detectors D and DC
19BAA249	Support ring	For concave cylindrical surfaces (R14 to 20 mm): for Detectors D and DC
19BAA250	Support ring	For convex spherical surfaces (R10 to 27.5 mm): for Detectors D and DC
19BAA251	Support ring	For concave spherical surfaces (R13.5 to 20 mm): for Detectors D and DC
19BAA457	Carbide ball	For Detectors D, DC, and D +15
19BAA458	Replacement ball shaft	For Detector DL

### External Output Devices

Code No.	Product Name	Specifications
264-506*	Digimatic Mini-Processor DP-1VA LOGGER	Test data printing
09EAA082	Recording paper	For DP-1VA LOGGER (10 rolls)
264-020	USB Input Tool IT-020U	Test data input unit
06AGL011	Connection cable (1 m)	
06AGL021	Connection cable (2 m)	
02AZD730G	U-WAVE-T	Data transmission unit, IP67 type
02AZD880G	U-WAVE-T	Data transmission unit, buzzer type
02AZD810D	U-WAVE-R	Data reception unit
02AZG011	Connection cable for dedicated use with U-WAVE-T (160 mm)	

\* To denote your AC line voltage, add the following suffixes. A for North America, D for Europe, E for the UK, K for Korea, DC for China, and no suffix is required for Japan.

## 3. Selectable Hardness Scale

Conversion to various hardness scales based on Leeb hardness values

### Detector Conversion Ranges

	Detector D	Detector DC
<b>Material</b>	<b>HV/Vickers</b>	<b>HB/Brinell</b>
Iron and steel	80 to 940	80 to 647
Alloyed tool-steel	80 to 898	—
Gray iron	—	93 to 334
Spherical graphite cast iron	—	131 to 387
Stainless steel	85 to 802	85 to 655
Brass	43 to 196	40 to 173
Casting copper-based alloys	—	45 to 315
Casting aluminum-based alloys	—	20 to 159
Copper-tin-based alloys	—	60 to 290

  

	Detector D +15
<b>Material</b>	<b>HV/Vickers</b>
Iron and steel	80 to 937
Tool steels for cold-work	80 to 935

  

	Detector DL
<b>Material</b>	<b>HV/Vickers</b>
Iron and steel	80 to 950

### External Dimensions

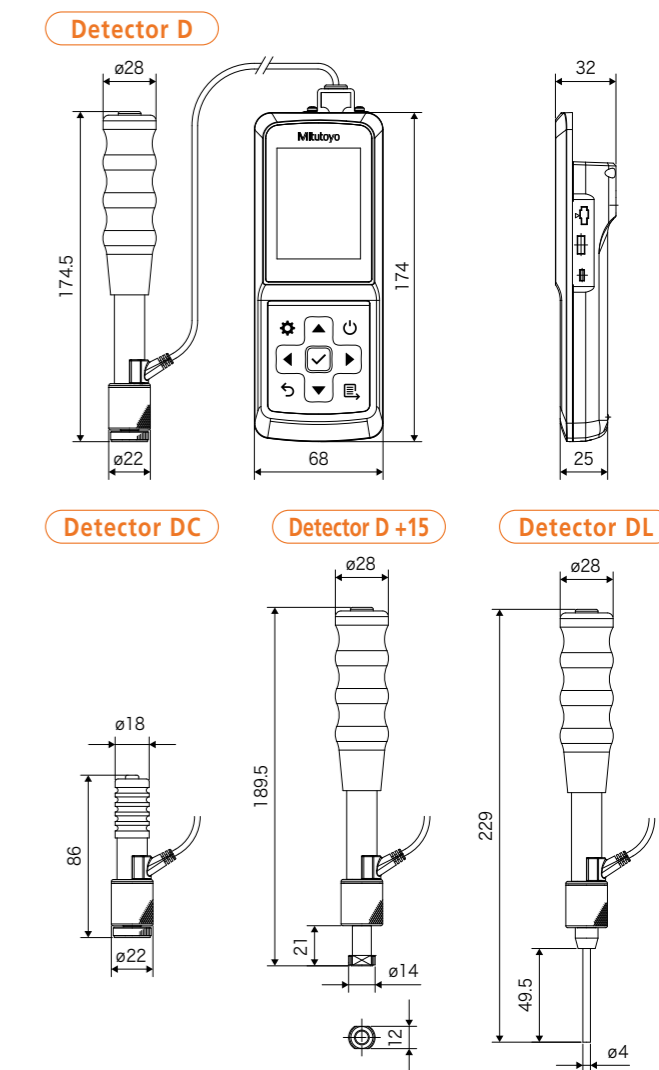

Unit: mm

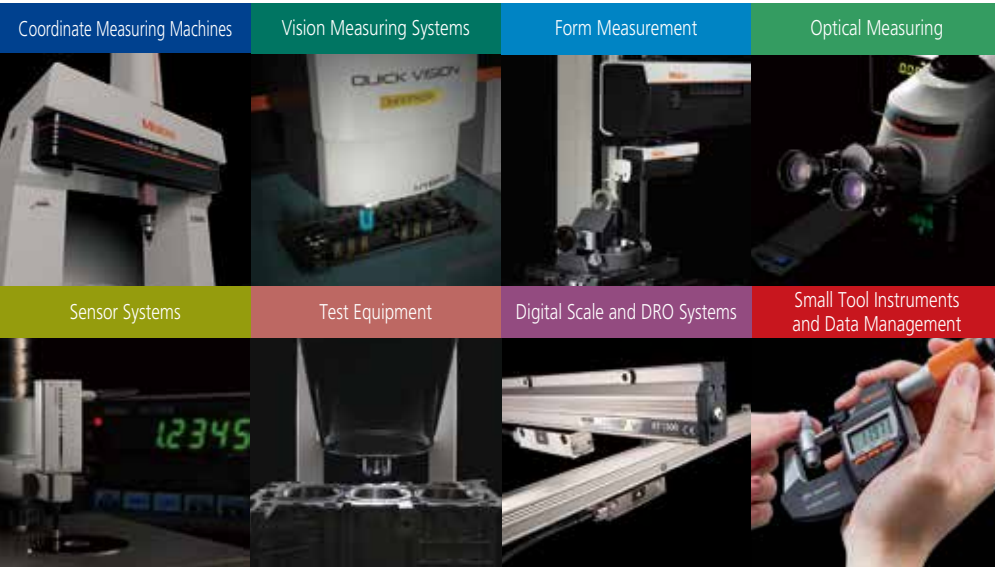

**Whatever your challenges are, Mitutoyo supports you from start to finish.**

Mitutoyo is not only a manufacturer of top quality measuring products but one that also offers qualified support for the lifetime of the equipment, backed up by comprehensive services that ensure your staff can make the very best use of the investment.

Apart from the basics of calibration and repair, Mitutoyo offers product and metrology training, as well as IT support for the sophisticated software used in modern measuring technology. We can also design, build, test and deliver measuring solutions and even, if deemed cost-effective, take your critical measurement challenges in-house on a sub-contract basis.



**Find additional product literature and our product catalog**

<https://www.mitutoyo.co.jp/global.html>

**Notes on Export Regulations:**

**Do not commit an act, which could directly or indirectly, violate any law or regulation of Japan, your country or any other international treaty, relating to the export or re-export of any commodities.**

Mitutoyo products are designed, manufactured and sold as industrial products that are intended for use at manufacturing sites. Mitutoyo reserves the right to change any or all aspects of any product specification, including prices, designs and service content, without notice.

Our product names, service names and logomarks used on this brochure are trademarks of Mitutoyo Corporation in Japan and other countries. Other product names and service names etc. may be trademarks or registered trademarks of their respective companies. All product information contained in this brochure is current as of August 2025.

# Mitutoyo

**Mitutoyo Corporation**

20-1, Sakado 1-Chome,  
Takatsu-ku, Kawasaki-shi,  
Kanagawa 213-8533, Japan  
<https://www.mitutoyo.co.jp>