

## Inspection Instrument for Indicators i-Checker



# For efficient in-house calibration Inspection Instrument for Indicators i-Checker



Bore Gages



Digimatic Indicators



Dial Indicators



Dial Test Indicators



Linear Gages



Electronic Micrometers

Various types of indicators can be inspected with a single tester.

## Features

- Inspection can be performed approx. 2.5 times faster compared to the previous model.
- This instrument guarantees ultra-reliable inspection results.
- Digital type indicators equipped with a data output function are checked very efficiently due to spindle positioning at the inspection points and recording of measurement results being under fully automatic control.
- Analog type indicators are inspected in semi-automatic mode with the pointer of the indicator being manually adjusted at each measuring point with automatic transfer of inspection results and movement to the next measuring point.

- The various standards, such as the latest standard for dial indicators, ASME and DIN, are applied. For the supported standards, see "Supported Industrial Standards" on page 6.
- Inspection standards to a customer's own specification can be implemented.

- A laptop PC can be connected using a USB cable, which contributes to space-saving.

- All functions necessary for inspection are combined in the control box so that the operator need not rely on excessive eye movement to adjust the pointer.



Inspection using analog type indicator



Inspection using digital type indicator

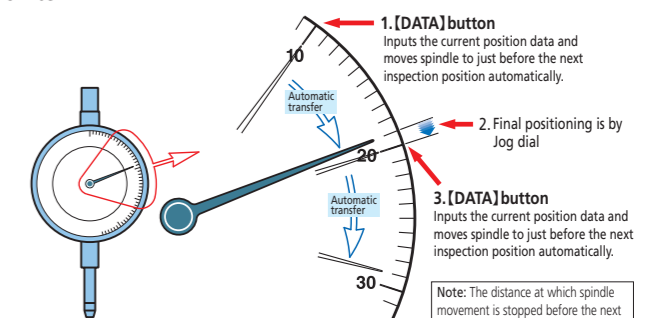
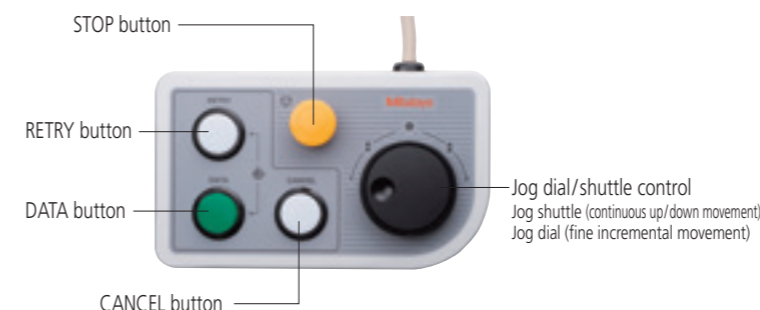
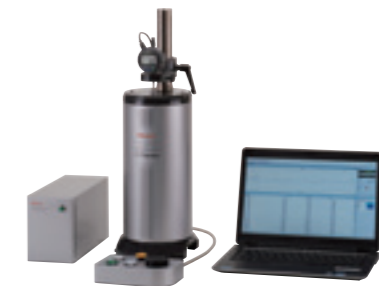
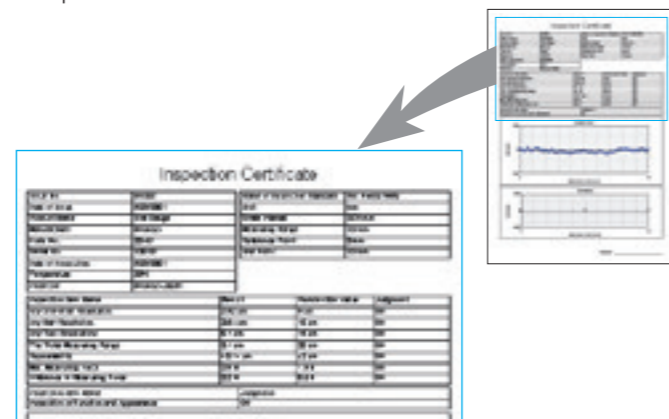

Note: The distance at which spindle movement is stopped before the next graduation is user-definable.

Optional Accessories and Applications

Applications for Bore Gage Accessory Set



Applications for bore gage measurement accessory set (type C)

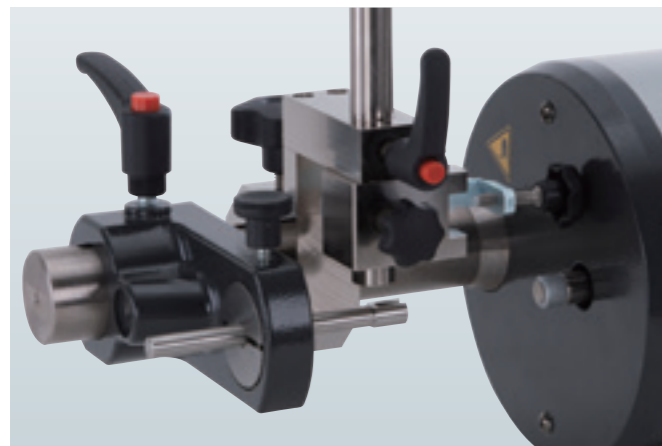

Application for mounting bore gage accessory set (type C)  
Order No. 02ASU162

i-Checker mountable bore gages

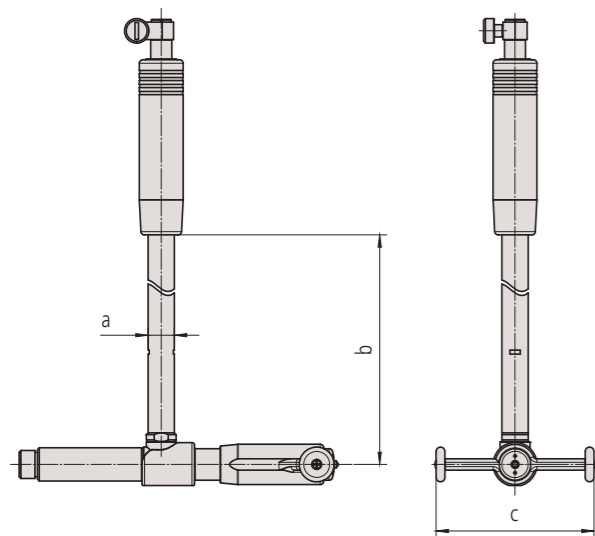

	Range (mm)
a	ø6 to ø18
b	50 or more
c	120 or less



List of components for bore gage accessory set (type C) Order No.02ASU162

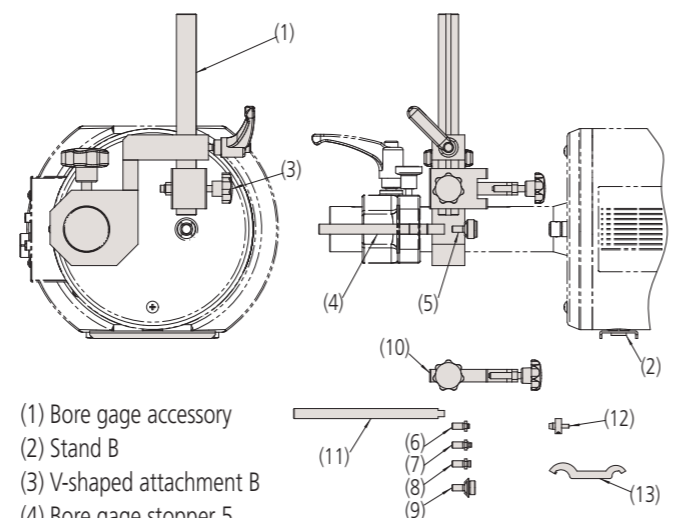

- (1) Bore gage accessory
- (2) Stand B
- (3) V-shaped attachment B
- (4) Bore gage stopper 5
- (5) Anvil (for calibration, M11 female)
- (6) Anvil (for calibration, M3.5x0.35 male)
- (7) Anvil (for calibration, M3.5x0.5 male)
- (8) Anvil (for calibration, M5 male)
- (9) Anvil (for calibration, M11 male)
- (10) V-shaped attachment C
- (11) Bore gage stopper 3
- (12) i-Checker's special contact point
- (13) Key wrench

Applications for Dial Test Indicator Accessory Set



Applications for dial test indicator accessory set (for horizontal type TI)



Applications for dial test indicator accessory set (for vertical type TI)



Dial Test Indicator Accessory Set (for ø6 stem)  
Order No.02ASK000

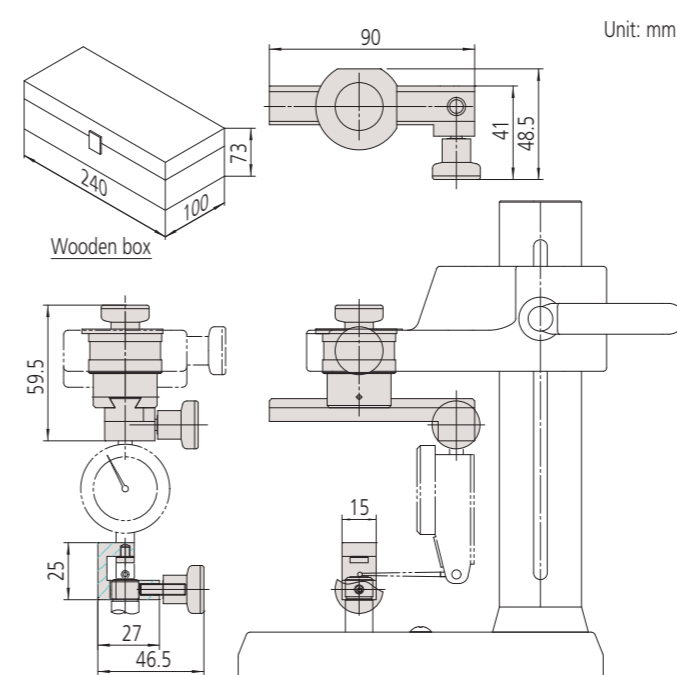

Supported Industrial Standards

	Dial Indicators	Dial Test Indicators	Hicators	Bore Gages	Digimatic Indicators	Linear Gages	Electronic Micrometers
ISO	463:2006 R463:1965	9493:2010	—	—	—	—	—
JIS	B7503:2017 B7503:2011 B7503:1997 B7503:1992	B7533:2015 B7533:1990	B7519:1994	B7515:1982	—	—	B7536:1982
JMAS	2001:1998 2001:1994 2003:1994	—	—	5009:1988	—	—	5003:1962
ANSI/ASME	B89.1.10M:2001 B89.1.10M:1987	B89.1.10M:2001 B89.1.10M:1987	—	—	B89.1.10M:2001	—	—
DIN	878:2006 878:1983	2270:2017 2270:1985	879:1983	—	—	—	—
VDI/VDE/DGQ	2618 Blatt11:1991	2618 Blatt11.3:2002 2618 Blatt20:1991	2618 Blatt21:1991	—	—	—	2618 Blatt26:1991
BS	907:1965	2795:1981	—	—	—	—	—
Mitutoyo Standard	—	—	—	—	✓	✓	—

\* "—" means that there are no applicable industrial standards.

Specifications

Model No.	IC2000
Measuring Range	100 mm
Resolution	0.01 μm
Accuracy	vertical position (0.1+0.4L/100) μm L=Arbitrary length (mm) lateral position (0.15+0.6L/100) μm L=Arbitrary length (mm)
Feed speed	Maximum 10 mm/s
Drive method	Motor drive, semi-automatic, fully automatic (Fully automatic only for Indicator with SPC data output)
Measuring Unit	Separate type Linear Encoder
Measurement method	Semi-automatic measurement Fully automatic measurement (only when using an indicator equipped with data output function)*1*2
Mass	20 kg
Operating temperature range	20 °C±0.5 °C

\*1 Fully automatic measurement requires the indicator's connecting cable. Additionally some form of indicator, along with the normally connected accessory (the optional accessory for the indicator such as a Digimatic power-supply unit in an EH counter) will be required.  
\*2 The indicator measured via RS-232C has the capability to receive data from the main unit and output the counter value.

Standard accessories supplied

Order No.	Item	QTY.
—	Tester main unit	1
—	Controller ICMC-2	1
02AST830	Control box	1
02ASU001	EXT. Signal Cable	1
02ASU002	EXT. Motor Cable	1
02ASU003A	EXT. USB2.0 Cable	1
02ASJ856	Stem bush 8 mm	1
02ASK091*3	Stem bush 9.525 mm	1
601614-2	Dust cover	1
99MBD063A	User's Manual (English)	1
—	Inspection certificate, Certification of calibration and Traceability chart (English)	1

\*3 When purchasing as single part, use the order No. 02ASK090.

Supported indicators

- Dial Indicators
- Dial Test Indicators
- Mitutoyo Hicators
- Bore Gages
- Digimatic Indicators
- Linear Gages
- Electronic Micrometers (Mu-Checker)

Note 1: It cannot inspect the indicator with accuracy that is higher than the main unit accuracy of the tester.

Note 2: Resolution of electronic micrometer (Mu-Checker) is greater than 1 μm (e.g. 1 μm/5 μm/10 μm/50 μm).

Dimensions

Unit: mm

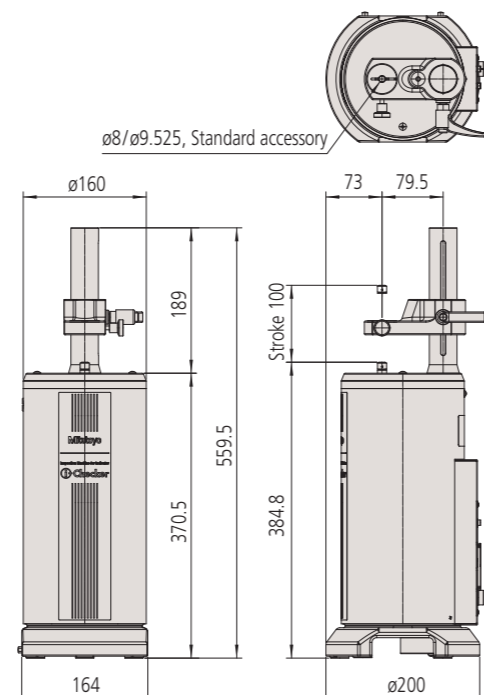

Required optional accessories  
Dedicated software (i-Pak specification)

• Supported OS

Windows10 (64 bit)  
Windows11 (64 bit)

• Supported Industrial Standards

ISO, JIS, JMAS, ANSI/ASME, DIN, VDI/VDE/DGQ, BS

• Basic inspection functions

- Creation of inspection standard conformed to the industrial standard
- Creation and edition of original inspection standard, by customizing the industrial standard
- Inspection of indicator using the inspection standard (inspection for accuracy and repeatability)
- Graphical display of measurement result
- Creation, edition, and printing of simplified inspection certificate

• Functions

- Retry "measurement positioning"
- Re-measurement
- Data cancellation
- Change of speed for jog shuttle

• Input/Output specifications

- Digimatic data connector (rear side of i-Checker main unit)\*
- PC serial-data input port (RS-232C)
- Generating, editing and printing of simplified inspection certificates

\* Fully automatic measurement requires the indicator's connecting cable. Additionally some form of indicator, along with the normally connected accessory (the optional accessory for the indicator such as a Digimatic power supply unit in an EF counter) will be required.

Optional accessories  
Attachments/Stem bush/Others/Connecting cables

Order No.	Item	Usage and remarks
Attachments		
02ASK000	Test indicator accessory set (for ø6 mm stem)	For attachment of ø6 stem test indicator
02ASK180	Test indicator accessory set (for ø8 mm stem)	For attachment of ø8 stem test indicator
02ASK370	Test indicator holder (for ø6 stem)	Holder to fix ø6 stem to 02ASK180
02ASK380	Test indicator holder (for ø8 stem)	Holder to fix ø8 stem to 02ASK000
21CZB128	ø6 dovetail grooved stem	Stem to attach Mu-Checker with knurled clamp ring (lever head type) to test indicator accessory set (02ASK000)
21CZB129	ø8 dovetail grooved stem	Stem to attach Mu-Checker with knurled clamp ring (lever head type) to test indicator accessory set (02ASK180)
02ASU162	Bore gage accessory set (type C)	Accessory set for holding grip type bore gage
Stem bushes		
02ASK040	Stem bush ø6	
02ASJ856	Stem bush ø8	
02ASK150	Stem bush ø8, short	For attachment of cartridge head MCHP-341
02ASL150	Stem bush ø10	
02ASK050	Bush ø9.5 to ø15	For attachment of LGB2 fixing nut type with stem diameter ø9.5 Stem bush (ø15 mm) is required separately.
02ASK060	Stem bush ø12	
02ASK070	Stem bush ø15	
02ASK080	Stem bush ø20	
02ASK710	Stem bush ø28	
02ASK090	Stem bush ø3/8 in	For attachment of indicator with stem diameter ø9.525 mm
02ASK130	Wooden box for stem bushes	Storage of 7 stem bushes and 1 bush (ø9.5 to ø15 mm)
Others		
937179T	Foot switch	Used instead of [DATA] button in the control box.
02ASK730	Observation mirror	
Connecting cables		
905338	Connecting cable (1 m)*1	Used for connecting with Digimatic Indicators (ID-C, ID-S, ID-U, and IDU)
905409	Connecting cable (2 m)*1	
936937	Connecting cable (1 m)*1	Used for connecting with Digimatic Indicators (ID-F, ID-F, Digimatic power supply unit and between the testers)
965014	Connecting cable (2 m)*1	
937387	Connecting cable (1 m)*1	Used for connecting with Digimatic Indicators (IDC and IDA)
965013	Connecting cable (2 m)*1	
21EAA194	Connecting cable (1 m)	Used for connecting with Digimatic Indicators (ID-B and ID-N)
21EAA190	Connecting cable (2 m)	
06AGL011	Connecting cable (1 m)	Used for connecting with Digimatic Indicators (ID-CNX and ID-FNX)
06AGL021	Connecting cable (2 m)	
965275	Digimatic power supply unit*2	Used for the Digimatic Indicators that require external power supply

\*1 Use the cable described in the user's manual.  
\*2 Confirm the specification in the user's manual.

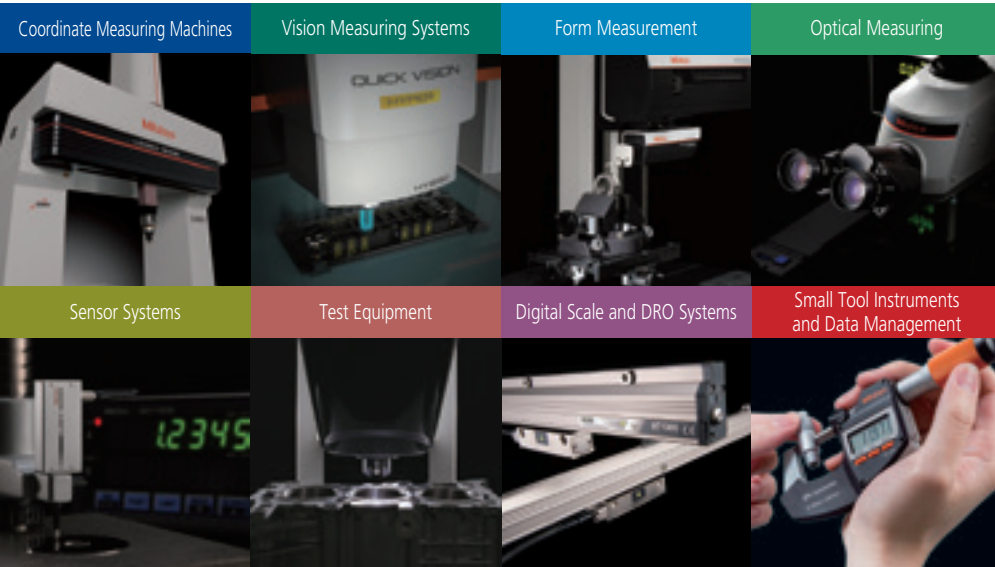

### Whatever your challenges are, Mitutoyo supports you from start to finish.

Mitutoyo is not only a manufacturer of top quality measuring products but one that also offers qualified support for the lifetime of the equipment, backed up by comprehensive services that ensure your staff can make the very best use of the investment.

Apart from the basics of calibration and repair, Mitutoyo offers product and metrology training, as well as IT support for the sophisticated software used in modern measuring technology. We can also design, build, test and deliver measuring solutions and even, if deemed cost-effective, take your critical measurement challenges in-house on a sub-contract basis.



Find additional product literature and our product catalogue

<https://www.mitutoyo.co.jp/global.html>

#### Notes on Export Regulations:

Do not commit an act, which could directly or indirectly, violate any law or regulation of Japan, your country or any other international treaty, relating to the export or re-export of any commodities.

Note: Product illustrations are without obligation. Product descriptions, in particular any and all technical specifications, are only binding when explicitly agreed upon.

MITUTOYO and MiCAT are either registered trademarks or trademarks of Mitutoyo Corp. in Japan and/or other countries/regions. Other product, company and brand names mentioned herein are for identification purposes only and may be the trademarks of their respective holders.

All product information contained in this brochure is current as of Nov. 2024.

# Mitutoyo

#### Mitutoyo Corporation

20-1, Sakado 1-Chome,  
Takatsu-ku, Kawasaki-shi,  
Kanagawa 213-8533, Japan  
T +81 (0) 44 813-8230  
F +81 (0) 44 813-8231  
<https://www.mitutoyo.co.jp>