

Ref No,511-39-2003-AUG

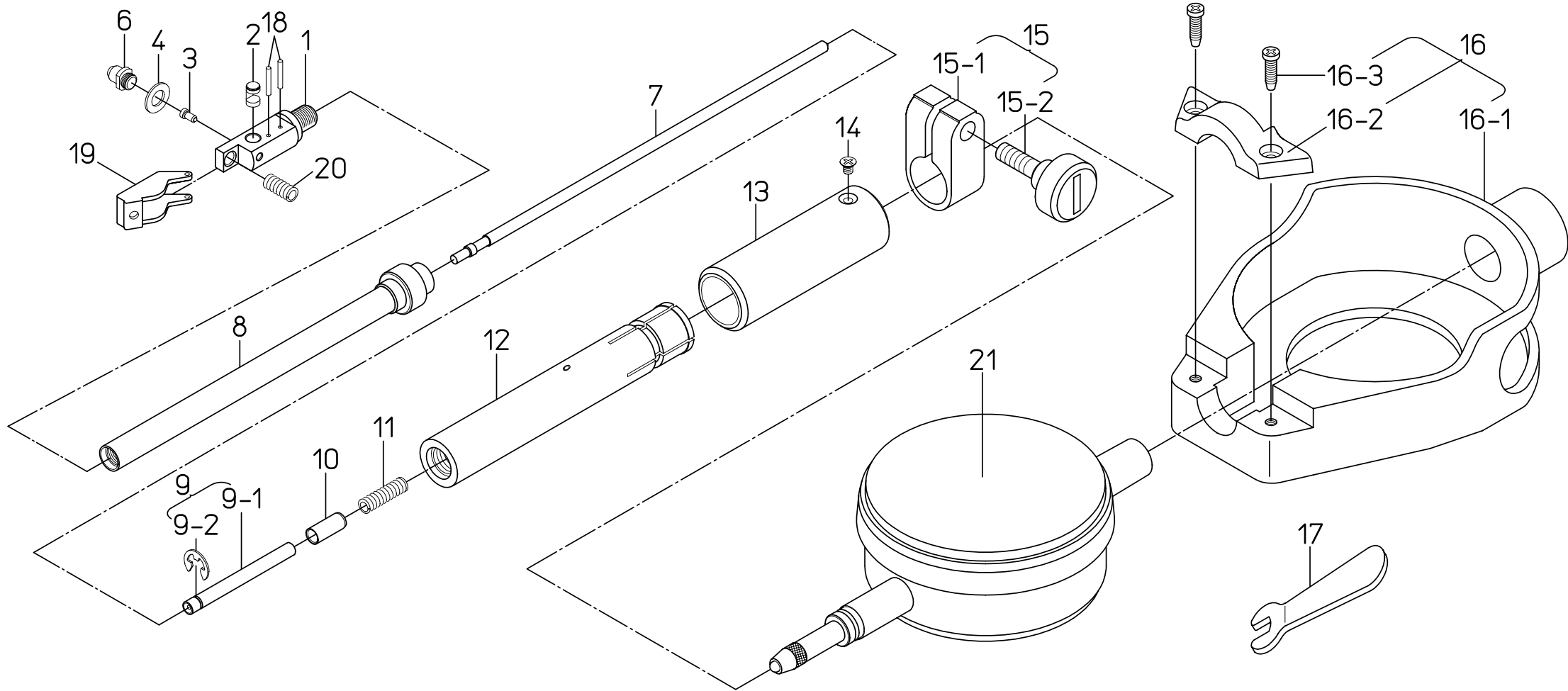

書類NO. 511-39

KEY NO,	ブヒンメイ	PART NAME	販売区分 CATEGORY	CODE NO, コードNo,						備考 COMMENTS
				511-201 Q	511-203 Q	511-204 Q	511-205 Q	511-206 Q	511-207 Q	
				CG-S18A			CG-S.74"A			
1	ホンタイ	BODY	X							このリストは、 コードNo.の後に "Q"が表示され ている製品に 適用されます。
2	カム	CAM	Y				204819			
3	ソクテイシ	CONTACT POINT	Y				204820			
4	カエワッシャ (0.5MM, .02")	WASHER (0.5MM, .02")					204355			
6	アンビル (10MM, .4")	ANVIL (10MM, .4")					204356			
	(11MM, .44")	(11MM, .44")					204357			
	(12MM, .48")	(12MM, .48")					204358			
	(13MM, .52")	(13MM, .52")					204359			
	(14MM, .56")	(14MM, .56")					204360			
	(15MM, .6")	(15MM, .6")					204361			
	(16MM, .64")	(16MM, .64")					204362			
	(17MM, .68")	(17MM, .68")					204363			
7	ドライバピン	DRIVING PIN					204817			
8	パイプ	PIPE	Y				903421			
9	ドライバロッドクミタテ	DRIVING ROD ASSY			204810			207257		
9-1	ドライバロッド	DRIVING ROD			204811			137091		
9-2	エトメワ	SNAP RING					21DAA013			
10	ストッパ	STOPPER					21DAA142			
11	スプリング	SPRING					204814			
12	ダイヤルホルダ	DIAL HOLDER	Y		902582			902673		
13	ニギリ	GRIP			902208			902211		
14	ジュウシアナツキサコネシ	SCREW					101280		ニギリ単体シリアル No.の刻印不能	
15	クランプホルダクミタテ	CLAMP HOLDER ASSY					902585			
15-1	クランプホルダ	CLAMP HOLDER					139662			
15-2	クランプネジ	CLAMP SCREW					139663			
16	ダイヤルホゴカハ-	PROTECTOR, DIAL					21DZA000			
16-1	カハ-	COVER					21DAA000		Key No.16は 511-201, 511- 205ではオプション	
16-2	オサエイタ	HOLDER					139484			
16-3	ジュウシアナツキナヘコネシ	SET SCREW					190007			
17	スパナ	SPANNER					204354			
18	ピン	PIN					204845			

Ref. No. 511-39-2003-AUG 1/2

511

BORE GAGES  
Series 511511シリーズ(CG-S)  
シリンダゲージ

511

書類NO. 511-39

KEY NO,	ブヒンメイ	PART NAME	販売区分 CATEGORY	CODE NO, コードNO,						備考 COMMENTS
				511-201 Q	511-203 Q	511-204 Q	511-205 Q	511-206 Q	511-207 Q	
				CG-S18A			CG-S.74"A			
19	ガイド	GUIDE	Y					204844		
20	ガイドスプリング	SPRING, GUIDE						204843		
21	ダイヤルゲージ	DIAL INDICATOR		-	2109FB	2046FB	-	2923FB	2922FB	
	【オプション】	【OPTION】								
6(W)	アンビル(W) (10MM, .4")	ANVIL(W) (10MM, .4")						204356	超硬合金	
	(11MM, .44")	(11MM, .44")						204357		
	(12MM, .48")	(12MM, .48")						204358		
	(13MM, .52")	(13MM, .52")						204359		
	(14MM, .56")	(14MM, .56")						204360		
	(15MM, .6")	(15MM, .6")						204361		
	(16MM, .64")	(16MM, .64")						204362		
	(17MM, .68")	(17MM, .68")						204363		
	(18MM, .72")	(18MM, .72")						204364		